

GLOBE VALVE STRAIGHT | NODULAR CAST IRON | DIN PN10

APPLICATION

Aboard ships for hot and cold water, fresh water, sea water, oil and steam.

MATERIAL SPECIFICATION

BODY : GGG40.3
BONNET : GGG40.3
SEAT : BRONZE
DISC : BRONZE
STEM : BRASS

TECHNICAL SPECIFICATION

MODEL : ECO. 263 (STOP TYPE)
ECO. 263-NR (SDNR TYPE)
CONNECTION : DIN PN10
CERTIFICATION : DNV-GL CLASS CERTIFICATE

DIMENSIONS SPECIFICATION

L : FACE TO FACE
D : F.O.D
C : P.C.D
NO : NUMBER OF HOLES
H : DIAMETER OF HOLES
W : WEIGHT

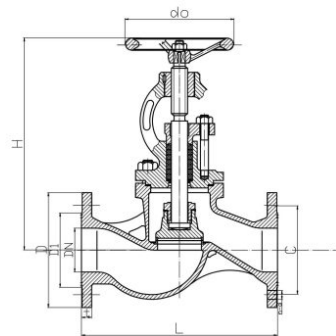

DIMENSION TABLE

CODE STOP	CODE SDNR	DN	L	D	C	NO	h	W
755401	755401-NR	15	130	95	65	4	14	4.5
755402	755402-NR	20	150	105	75	4	14	5.5
755403	755403-NR	25	160	115	85	4	14	8.5
755404	755404-NR	32	180	140	100	4	18	9
755405	755405-NR	40	200	150	110	4	18	12.5
755406	755406-NR	50	230	165	125	4	18	15.5
755407	755407-NR	65	290	185	145	4	18	22
755408	755408-NR	80	310	200	160	8	18	27.5
755409	755409-NR	100	350	220	180	8	18	38.5
755410	755410-NR	125	400	250	210	8	18	60
755411	755411-NR	150	480	285	240	8	22	83
755413	755413-NR	200	600	340	295	8	22	127
755414	755414-NR	250	730	395	350	12	22	255
755415	755415-NR	300	850	445	400	12	22	355



VALVE TURKIYE

+90 232 616 17 19
valves@adamarine.com

VALVE EUROPE

+31 180 22 4000
valves.nl@adamarine.com

VALVE ASIA

+86 186 2606 6553
valves.ch@adamarine.com

www.marinevalves.com